



ITT

Water & Wastewater

Flygt DXG

Reliable residential grinder!



Twenty five years in grinder development has resulted in the new Flygt DXG. This residential grinder turns all solid matter into sludge. No more blocked sewage – no more problems!



Engineered for life

No more stoppage!

- Designed-protected cutter wheel for highly efficient cutting
- Cutter wheel and cutter plate in hardened stainless steel
- Patented easy trim of cutting device for easy service
- Dry motor for submersible duty with class F winding
- Built-in capacitor and float switch (1-phase version)

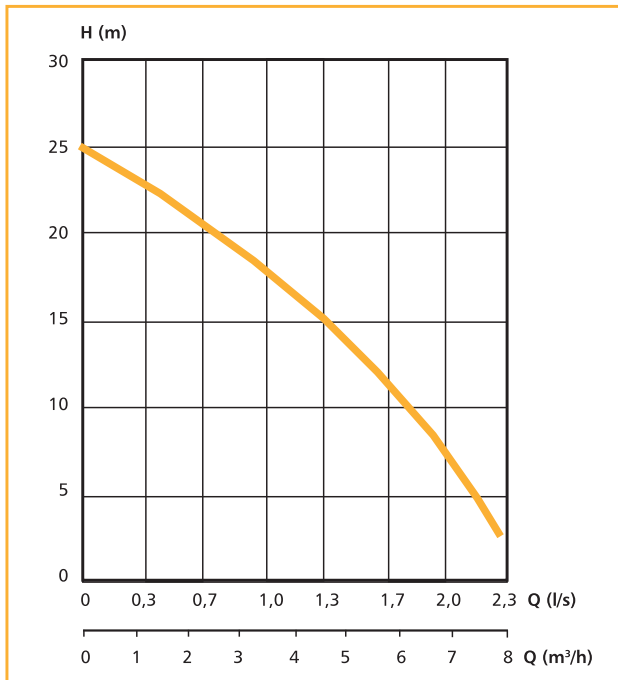

Stationary installation suspended from a discharge pipe and fitted with an outlet bend. Here in a Flygt Compit station.

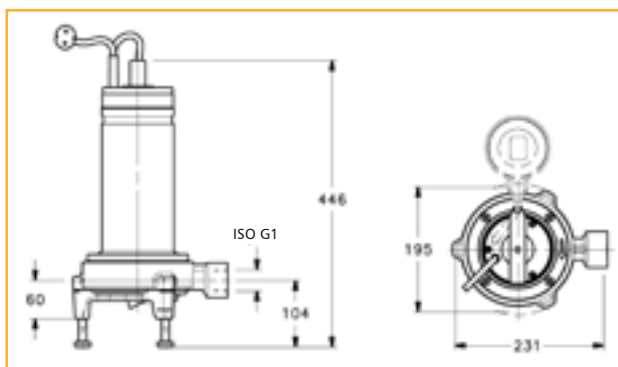

Stationary wet installation directly to a discharge connection using guide bars when fitted with a sliding bracket. Here in a Flygt Micro 7 station.

Pump version	Power	Phase	Input Current		Capacitor	Weight	Cable length
			220-240 V	380-415 V			
DXG 25-11	1.1 kW	3-phase	4.7	2.7		18.3 kg	10 m
DXGM 25-11	1.1 kW	1-phase	7.0		30 µF. 450V	19 kg	10 m

ITT Water & Wastewater AB
 SE-174 87 Sundbyberg
 Visiting address:
 Gesällvägen 33
 Tel +46-8-475 60 00
 Fax +46-8-475 69 00

www.ittwww.com